

# Spring loaded thermocouple

THERMOWELL & REPLACEABLE INSERT

**C500-501-504-505-560-562**  
**CONFIGURATIONS**

**Ex ia TC**

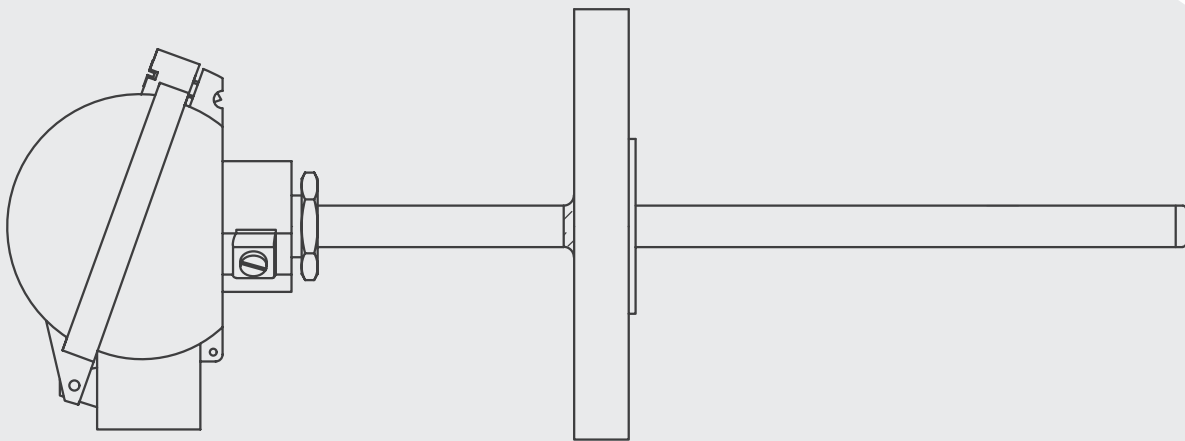

**RODAX**<sup>o</sup>  
new temperature solutions

Product series TCRI/WI

C500

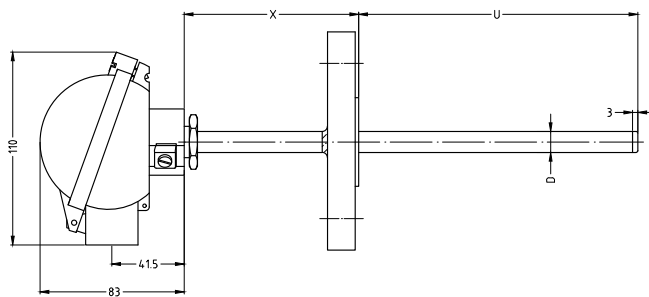

C501

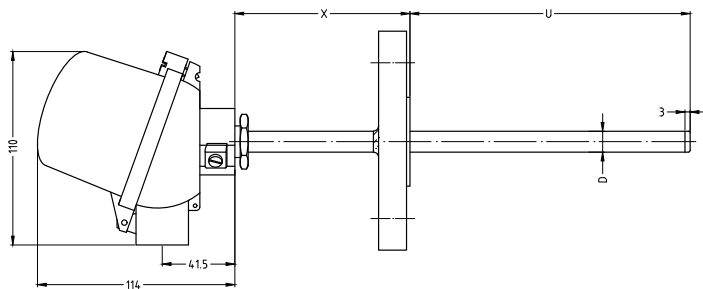

C504

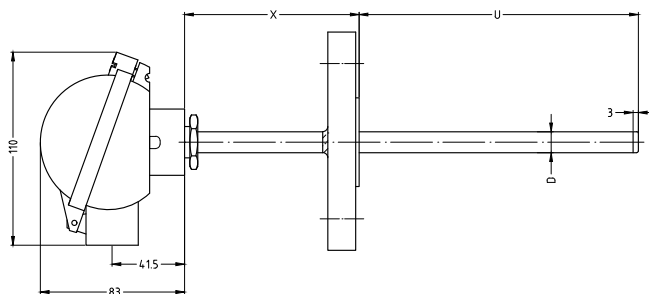

C505

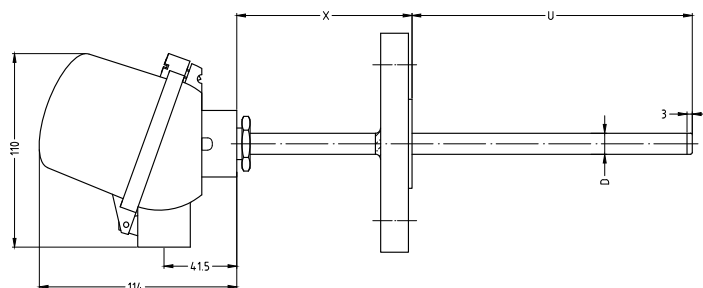

C560

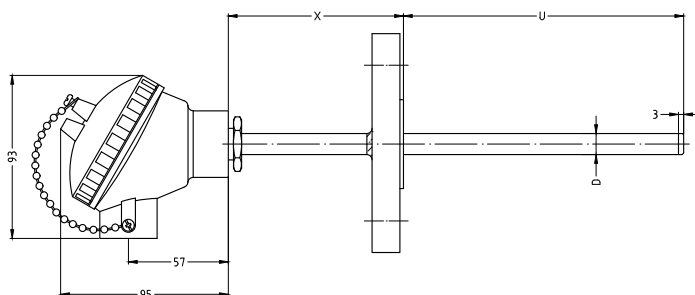

C562

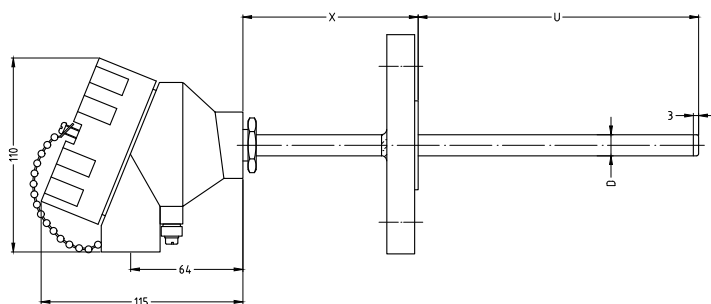

## Features assembly

The industrial spring loaded configuration guarantees a positive contact between the sensing part of the temperature probe and the bottom of the thermowell, thus reducing the response time.

Flanged process connection.

The assemblies can be delivered with an aluminium or stainless steel connection head combined with a high quality thermocouple element with MgO mineral insulated metal sheathed cable, providing excellent stability and reproducibility.

Sensor diameters up to 12,7 mm.

## Technical specification assembly

- Connection head aluminium (C500-C501-C504-C505-C560-C562) with external earth.
- Ambient temperature range assembly: -45/+80 °C; this can be limited depending on the materials applied or in case a temperature transmitter is used.
- IP-68 protection degree (body – cover) with silicone rubber O-ring. The assembly protection degree (IP-68) can be attained but depends on the use of correct cable gland(s) and on the correct mounting to thermowells.
- Cover: hinged type or screw type with chain.
- Several sensor diameters and lengths are possible.

**Table 1: Configuration**

## Connection head type

Choice between:

- Connection head types C500 / C501 / C504 / C505 with hinged type cover with 1 or 2 conduit openings.
- Connection head types C560 / C562 with screw type cover with 1 or 2 conduit openings.
- Connection head supplied with O-ring in silicone rubber (between body and cover). Head supplied with external earth terminal.

	Conduit	Material	Coating	Colour
<b>C500</b>	00C1 1x conduit	Aluminium	Epoxy Corrosion category EN ISO 12944-2: C4	RAL5015 Sky blue
<b>C501</b>	01C1 1x conduit	Aluminium	Epoxy Corrosion category EN ISO 12944-2: C4	RAL5015 Sky blue
<b>C500/501</b>	00C2/01C2 2x conduits	Aluminium	Epoxy Corrosion category EN ISO 12944-2: C4	RAL5015 Sky blue
<b>C504</b>	04S1 1x conduit	Polyamide PA12 (Antistatic)	None	Black
<b>C505</b>	05S1 1x conduit	Polyamide PA12 (Antistatic)	None	Black
<b>C560</b>	60C1 1x conduit	Aluminium	Epoxy Corrosion category EN ISO 12944-2: C4	RAL5015 Sky blue
<b>C562</b>	62C2 2x conduits	Aluminium	Polyurethane spray on primer Corrosion category EN ISO 12944-2: C5-M	RAL5015 Sky blue

**Table 2: Measuring inserts main models**

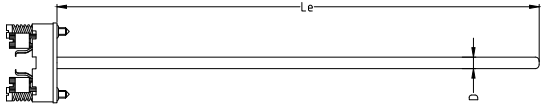
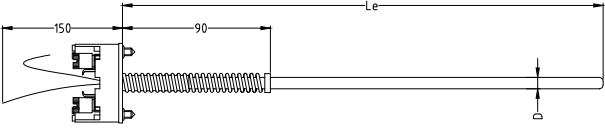
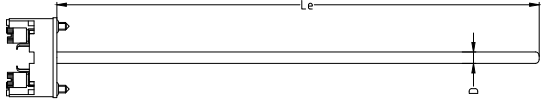
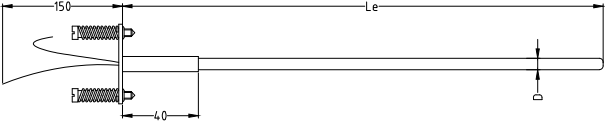
	<b>Terminal</b>	<b>Total spring</b>	
<b>TCCC</b>	Ceramic spring loaded terminal block 2/4/6 or 8 terminals	10 mm  We recommend a spring loading of +/-5 mm	
<b>TCCB</b>	Hi-tech spring loaded thermoplast (moisture and shock proof) terminal block 2/4 or 6 terminals	40 mm  We recommend a spring loading of +/-20 mm	
<b>TCCA</b>	Hi-tech spring loaded thermoplast (moisture and shock proof) terminal block 2/4 or 6 terminals	10 mm  We recommend a spring loading of +/-5 mm	
<b>TCFA</b>	Spring loaded mounting plate with flying leads of 150 mm	10 mm  We recommend a spring loading of +/-5 mm	

**Table 3: Equipment for potentially explosive atmospheres**

**Certification**

<b>A</b>	ATEX
<b>I</b>	IECEX
<b>G</b>	GOST-R

**Explosive atmosphere**

<b>G</b>	Gas
<b>D</b>	Dust

**Table 4: Measuring inserts details**

## Details

- Thermocouple types: J/K/T/E/N/S/R/B
- Thermocouple standards: EN/IEC 60584 and/or ANSI MC96-1
- Minimum insulation resistance: 1000 MOhm at 500VDC,  $T_{amb}=20\text{ °C}$
- Conductors: thermocouple material
- Metal sheath: see table

## TC Type

<b>J</b>	<b>K</b>	<b>T</b>	<b>E</b>	<b>N</b>
Fe – CuNi	NiCr – NiAl	Cu – CuNi	NiCr – CuNi	NiCrSi – NiSi
±1.5 between -40 °C and 375 °C or ±0.004xT °C	±1.5 between -40 °C and 375 °C or ±0.004xT °C	±0.5 between -40 °C and 125 °C or ±0.004xT °C	±1.5 between -40 °C and 375 °C or ±0.004xT °C	±1.5 between -40 °C and 375 °C or ±0.004xT °C

## Colour code

<b>ANSI</b>	<b>IEC</b>	<b>Other</b>
ANSI – MC96-1	EN/IEC 60584-1	

## TC element

<b>S</b>	<b>D</b>	<b>T</b>
Single thermocouple	Dual thermocouple	Triple thermocouple

## Diameter ØD

<b>D3</b>	<b>D3,2</b>	<b>D4,5</b>	<b>D4,8</b>	<b>D6</b>	<b>D6,35</b>	<b>D8</b>	<b>D9,53</b>	<b>D12,7</b>	<b>Other diameters on request</b>
3,0 mm	3,2 mm	4,5 mm	4,8 mm	6,0 mm	6,35 mm	8,0 mm	9,53 mm	12,7 mm	

## Sheath material

<b>M2102</b>	<b>M2107</b>	<b>M2110</b>	<b>M0601</b>	<b>M0701</b>	<b>M0704</b>	<b>M0809</b>
SS304	SS316 Standard for TC J/T	SS310	Inconel 600 Standard for TC K	Alloy 800H	Alloy 825	Hastelloy X

## Hot junction

<b>I</b>	Individually isolated	Hot junction electrically isolated from and shielded by the sheath.
<b>CI</b>	Commonly isolated	Multiple hot junctions joined to one hot junction electrically isolated from and shielded by the sheath.
<b>DI</b>	Dually isolated	Hot junction electrically isolated from and shielded by the sheath. For dual and triple: all circuits isolated from each other and from the sheath.
<b>G</b>	Grounded	Hot junction welded to the sheath.

**Table 5: Thermowell–Protection tube**

## Protection tube

Stainless steel tube with 3 mm welded plug with rotatable or not-rotatable connection to head.

## Material Protection tube

<b>M2108</b>	<b>M2102</b>	<b>M2110/8</b>	<b>M0601</b>	<b>M0805</b>	Other materials on request
SS316L	SS304L	SS310/310S	Inconel 600	Hastelloy C276	

## Dimensions Protection tube

<b>D0610</b>	<b>D0810</b>	<b>D1015</b>	<b>D1215</b>	<b>D1425</b>	Other dimensions on request
6 mm OD x Wall 1 mm	8 mm OD x Wall 1 mm	10 mm OD x Wall 1,5 mm	12 mm OD x Wall 1,5 mm	14 mm OD x Wall 2,5 mm	

## Positioning connection head

<b>YR</b>	Rotatable connection head
<b>NR</b>	Fixed connection head

## Dimensions extension tube

OD tube		X
<b>STD</b>	... mm	<b>X</b>
Same as tube	Reinforced	Length in mm

## Insertion length

<b>U</b>	Length in mm
----------	--------------

## Flange details according to ANSI B16.5

Pressure rating (lbs/inch <sup>2</sup> )	<b>1</b>		<b>2</b>		<b>3</b>		
	150#		300#		600#		
Nominal size	<b>05</b>	<b>06</b>	<b>07</b>	<b>09</b>	<b>10</b>	<b>11</b>	<b>12</b>
	1/2"	3/4"	1"	1 1/2"	2"	2 1/2"	3"
Flange facing	<b>RF</b>	Raised face					
	<b>FF</b>	Flat face					
	<b>RTJ</b>	Ring type joint					
Surface finish	<b>SF</b>	Smooth finish 3,2-6,3 µm (125-250 µ inch)					
	<b>ST</b>	Stock finish 3,2-12,5 µm (125-500 µ inch)					
	Other on request						

## Flange details according to EN 1092-1

Pressure rating (PN)	<b>1</b>		<b>2</b>		<b>3</b>		<b>4</b>		<b>5</b>		<b>6</b>		<b>7</b>		
	PN 6		PN 10		PN 16		PN 25		PN 40		PN 63		PN 100		
Nominal size (DN)	<b>D04</b>	<b>D05</b>	<b>D06</b>	<b>D07</b>	<b>D08</b>	<b>D09</b>	<b>D10</b>	<b>D11</b>	<b>D12</b>	<b>D13</b>	<b>D14</b>	<b>D15</b>	<b>D16</b>		
	DN10	DN15	DN20	DN25	DN32	DN40	DN50	DN65	DN80	DN100	DN125	DN150	DN200		
			<b>Flange facing</b>						<b>Surface finish (RA)</b>						
<b>Flange facing &amp; Surface finish (RA)</b>			<b>A</b>	Flat face						3,2-12,5 µm max					
			<b>B1</b>	Raised face PN10 to PN40						3,2-12,5 µm max					
			<b>B2</b>	Raised face PN63 to PN100						0,8-3,2 µm max					
			<b>C</b>	Tongue						0,8-3,2 µm max					
			<b>D</b>	Groove						0,8-3,2 µm max					
			<b>E</b>	Project						3,2-12,5 µm max					
			<b>F</b>	Recess						3,2-12,5 µm max					

Table 6: Connection head details

## Connection head single/double conduits (SC/DC)

<b>SC173</b>	<b>SC405</b>	<b>DC173</b>	<b>DC405</b>
1X M20x1.5	1X 1/2"NPT	2x M20x1.5	2X 1/2"NPT

**Table 7: Connection head accessories**

## Available options

- **Option 1: For SC and DC connection heads: Cable gland(s) only**

If required, a cable gland can be supplied; please use the letter 'CG' (cable gland) followed by the material of the cable gland and used cable diameter. Specification see below table.

The offered cable glands are II2 G Ex d/e IIC Gb and II 2D Ex tb IIIC Db IP66 certified and can be combined with configured products in this datasheet.

For SC heads, only option 'one cable gland' is possible. For DC heads, both one and two cable glands are possible.

- **Option 2: For DC connection heads: One conduit plugged**

Please use the letter 'P' (plug) followed by the material of the plug, see below table. The remaining conduits stay open.

- **Option 3: For DC connection heads: Cable gland + one conduit plugged**

Please use the combination 'PCG' (plug cable gland) followed by the material of the plug and cable gland, see below table.

		Option 1	Option 2	Option 3
<b>Material</b>	Brass	<b>CGM0200</b>	<b>PM0200</b>	<b>PCGM0200</b>
	Nickel plated brass	<b>CGM0210</b>	<b>PM0210</b>	<b>PCGM0210</b>
	Stainless steel SS316	<b>CGM2107</b>	<b>PM2107</b>	<b>PCGM2107</b>
	Polyamide	<b>CGM5006</b>		<b>CGM5006</b>
<b>Cable diameter for EPDM rubber</b>	4 - 7 mm	<b>D5</b>		<b>D5</b>
	7 - 9,5 mm	<b>D8</b>		<b>D8</b>
	9 - 12 mm	<b>D10</b>		<b>D10</b>
	7 - 13 mm	<b>D9</b> (only for CGM5006)		<b>D9</b> (only for CGM5006)
<b>Glands N°</b>	One cable gland	<b>N1</b>		
	Two cable glands	<b>N2</b>		



**Table 8: Certification possibilities**

## Certificates

Following tests and certificates are possible and are either done in-house or done by an external party.

Code	Certificates
<b>Q04210</b>	Functional test report sensor
<b>Q04230</b>	Calibration report (measuring points to be indicated) E.g. 100/200 °C
<b>Q05220</b>	Calibration report by accredited calibration lab retraceable (measuring points to be indicated)
<b>Q05230</b>	Calibration report by accredited calibration lab ISO/IEC 17025 (BELAC) (measuring points to be indicated)
<b>Q02040</b>	Test report EN10204-2.2
<b>Q04250</b>	Transmitter programming. Range and burn-out settings to be indicated



## Addenda

### Thermal data related to product series TCRI/WI

The maximum process temperature  $T_p$  (in °C) and the relation to the temperature class is as follows:

<b>Maximum process temperature <math>T_p</math> (°C)</b>	75	90	125	190	285	435	>435
<b>Temperature class (°C)</b>	T6	T5	T4	T3	T2	T1	$T_p+10$
<b>Maximum surface temperature T of the Assembly (°C)</b>	85	100	135	200	300	450	$T_p+10$

### Certificates for product series TCRI/WI

<b>ATEX 2014/34/EU</b>	ATEX EU-type examination certificate 18ATEX0060 X	
<b>IECEX 02</b>	IECEX DEK 18.0032 X	
<b>GOST-R</b>	GOST EAC RU C-BE.ГБ05B.00211	

## HOW TO ORDER (example)

Code		Example	Your code
<b>Configuration</b>	See table 1	C501	
<b>Main model</b>	See table 2	KCA	
<b>Certification</b>	See table 3	A	
<b>Explosion atmosphere</b>	See table 3	G	
<b>TC type</b>	See table 4	K	
<b>Colour code</b>	See table 4	IEC	
<b>TC element</b>	See table 4	D	
<b>Diameter ØD</b>	See table 4	D6	
<b>Sheath material</b>	See table 4	M0601	
<b>Hot junction</b>	See table 4	I	
<b>Material protection tube</b>	See table 5	M2108	
<b>Dimensions protection tube</b>	See table 5	D1215	
<b>Positioning connection head</b>	See table 5	YR	
<b>Insertion length U (mm)</b>	See table 5	U200	
<b>Pressure rating</b>	See table 5	1	
<b>Nominal size</b>	See table 5	07	
<b>Flange facing / Surface finish</b>	See table 5	RF SF	
<b>Dimensions extension tube</b>	See table 5	STD	
<b>Extention length X</b>	See table 5	X100	
<b>Connection head SC/DC</b>	See table 6	DC173	
<b>Connection head accessories</b>	See table 7	CGM0200D5N2	

Ordering code example:

C501 KCA A G K IEC D D6 M0601 I M2108 D1215 YR 1 07 RF SF STD X100 U200 DC173 CGM0200D5N2

**For all options: please contact Rodax**

© 2018

Santvoortbeeklaan 33, 2100 Antwerp - Belgium

T +32 (0)3 360 90 00

E [quotationdesk@rodax-europe.com](mailto:quotationdesk@rodax-europe.com)

[www.rodax-europe.com](http://www.rodax-europe.com)

**RODAX**<sup>®</sup>  
new temperature solutions

All information contained herein is intended for guidance purposes only, and characteristics of the products and certification described in this publication can be changed at any time without notice. Products and certification may not be available for your local area. Please contact your local sales representative for availability information. RODAX NV diligently strives to provide as accurate information as possible, but shall not be responsible for any typographical error.

**C500-Exia-TC GB 201901**