

CERAMIC THERMOWELL

SILICIUM CARBIDE HEXOLOY[®]

THREADED

THT

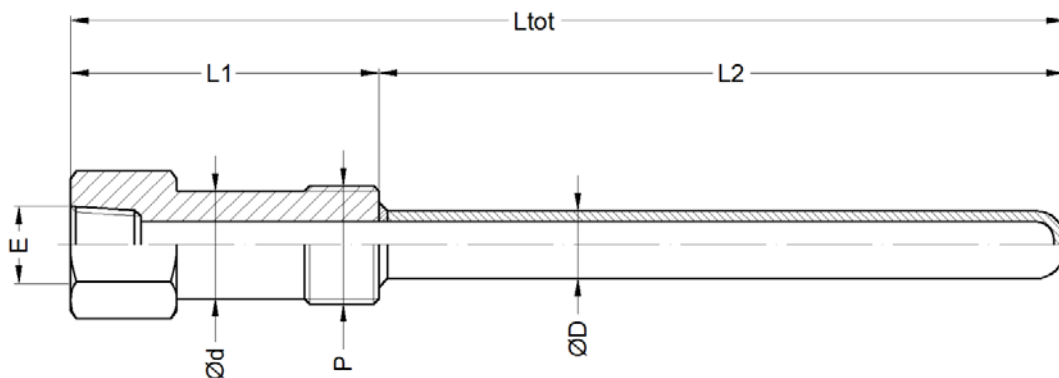

Features

Hexoloy[®] SA SiC is produced by pressureless sintering submicron silicon carbide powder. The sintering process results in a self-bonded, fine grain (less than $10\mu\text{m}$) SiC product which is extremely hard, lightweight and low in porosity. The material can be formed into complex shapes with greater than 98% theoretical density.

Corrosion Resistance

The corrosion resistance of Hexoloy[®] SA SiC permits superior performance in environments of hot gasses and liquids including strong acids and bases, even at extremely high temperatures. The results indicate that by comparison Hexoloy[®] SA SiC outperforms tungsten carbide and aluminum oxide in all chemical categories. The ability of Hexoloy[®] SA SiC to resist corrosion along with its excellent surface finish characteristics makes it ideally suited to applications involving heat exchangers, mechanical seal faces, valves, bearings and other mineral and chemical processing equipment components.

Erosion Resistance

Erosion resistance is usually associated with high hardness. Hexoloy[®] SA SiC is 50% harder than tungsten carbide and ten times harder than conventional stainless steel. This extreme hardness combined with high purity and fine microstructure makes Hexoloy[®] SA SiC particularly resistant to wear and erosion under mechanically abrasive conditions. The results are tested in accordance with ASTG 76. The test results clearly demonstrate the superiority of Hexoloy[®] SA SiC, especially at higher impingement angles. Hexoloy[®] SA SiC's excellent erosion and wear resistant properties make it ideally suited for sand blast and spray nozzles, abrasion resistant linings and mechanical seal and bearing surfaces.

High Temperature Properties

The single phase composition of Hexoloy[®] SA SiC enables it to reliably perform in air at temperatures in excess of 1900°C (3450°F). Where dimensional changes at high temperature are a concern, Hexoloy[®] SA SiC has a consistently low coefficient of thermal expansion. This feature allows design flexibility for shrink fit or leak-tight joint applications. Oxidation resistance is also important for certain high temperature applications.



Hexoloy® SA SiC, due to its high purity and high density, is more stable in longterm applications because it is more oxidation resistant. A protective coating of SiO₂ is formed on the surface of SiC which slows the oxidation process.

Thermal Shock

Because of its high thermal conductivity and low coefficient of thermal expansion, it is very resistant to thermal shock and will survive rapid thermal cycling as compared to other refractory materials. Typical thermal applications include thermocouple protection tubes, kiln beams, burner components and other furnace and high temperature applications

Flexural Strength

Hexoloy® SA SiC exhibits excellent strength at room temperature and maintains that strength even at elevated temperatures as depicted above due to its single phase fine grain structure.

Technical specifications

- Hardness (Knoop): 2800 kg/mm²
- Thermal conductivity: 200°C: 102.6W/m.K and 400°C: 77.5 W/m.K
- Permeability at RT1000°C : impervious to gases over 31MPa

Ordering information

Support Material	M2108	M2110	M2202	M0703	Note: Flange material will be delivered as standard SS316L unless otherwise specified.
	SS316L	SS310	SS446	Incoloy 800HT	
	1.4404	1.4841	1.4762	1.4959	

Process Connection	E205	E405	E206	E406	E207	E407	E408	E409
	G1/2"	1/2" NPT	G3/4"	3/4" NPT	G1"	1" NPT	1 1/4" G	1 1/2" NPT
	Minimum SW	Minimum SW	Minimum SW	Minimum SW	Minimum SW	Minimum SW	Minimum SW	Minimum SW
	SW 27	SW27	SW36	SW36	SW36	SW36	SW50	SW50

Instrument Connection	E205	E405	E206	E406
	1/2" G	1/2" NPT	3/4" G	3/4" NPT
	L1 minimum length			
	150 mm			

Form	Code	Hexoloy OD-ID		L max	Minium support diameter OD/ID	Minimum support length
		inches	mm	mm	mMm	mm
	01	5/8"-3/8"	15-9.53	650	d24/19	150
	02	3/4"-1/2"	19 -12.7	1200	d27/23	150
	03	1" -1/2"	25.4-12.7	1200	d30/26	150

Code	Certificates
Q701MC	Material certificate for flange and extension *
Q665NT	PMI testing after construction by third party (on support tube and flange)
Q820CC	Test report EN10204-2.2 .

*EN10204-3.1 material certificate is NOT available for SiC material. You can use A 10204-2.2 test certificate.

HOW TO ORDER (example)			
Code	Description	Example	Your code
Type	Thermowell type	THT	
Material Support tube	Support tube material SS316L	M2108	
Material Flange	Flange material (if other than stem)		
Process connection	¾"NPT	P406	
Instrument connection	Connection for the instrument ½"NPT	E405	
Code	Diameter Hexoloy ex. 15 mm	01	
L2	Length Hexoloy tube in mm	L2=400	
Size support tube	SW or diameter support tube	SW36	
L1	Length top including thread	L1=150	
L total	Total length construction L1+L2+L3	L=550	
Certificate	Test certificate EN10204-2.2	Q820CC	

Ordering example

THT M2108 P406 E405 01 L2=400 SW36 L1=150 L=550 Q820CC

For all options: please contact Rodax